

Koaxiální reproduktor B&C Speakers 12CXL

Doporučená výhybka:

B&C Speakers XO-2

<http://eshop.prodance.cz/DetailPage.asp?DPG=78581>

První 4 strany měřeny s:

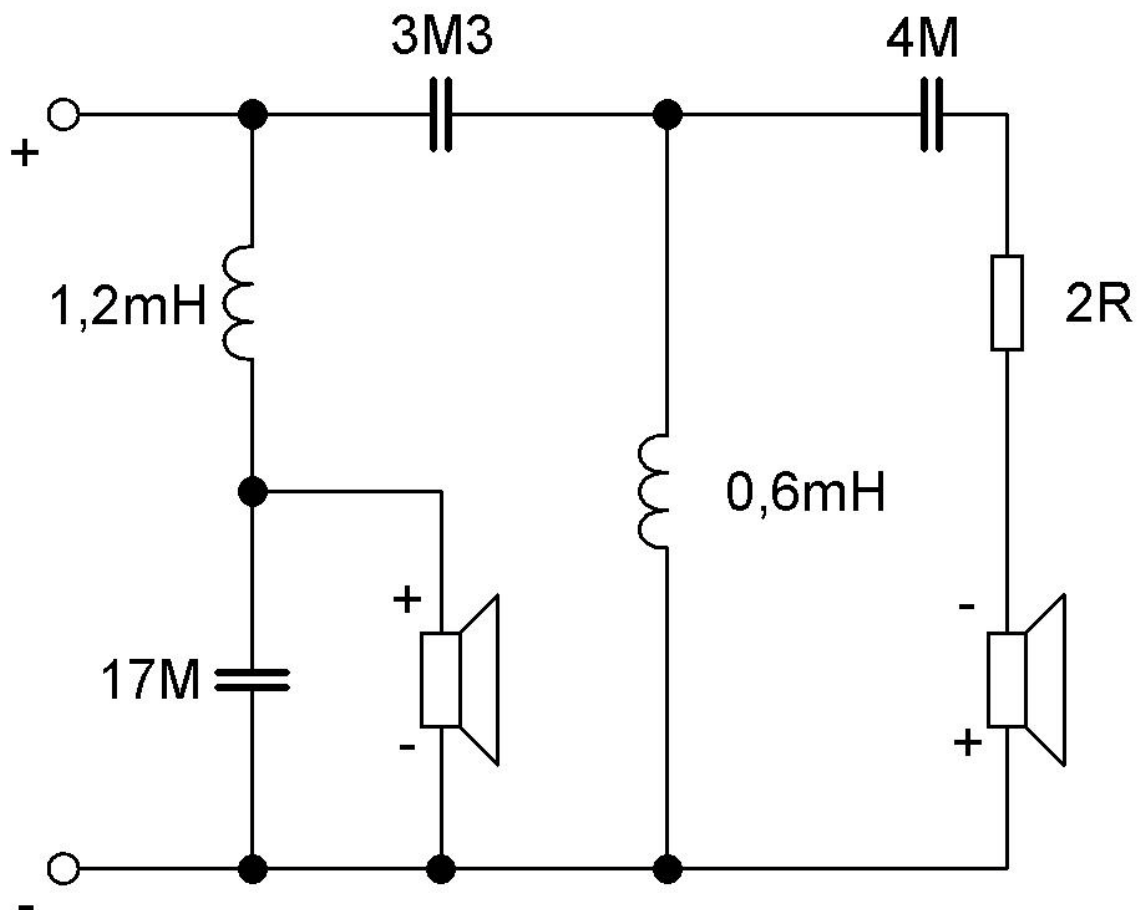

Strana 5. a 6. měřena s XO-2

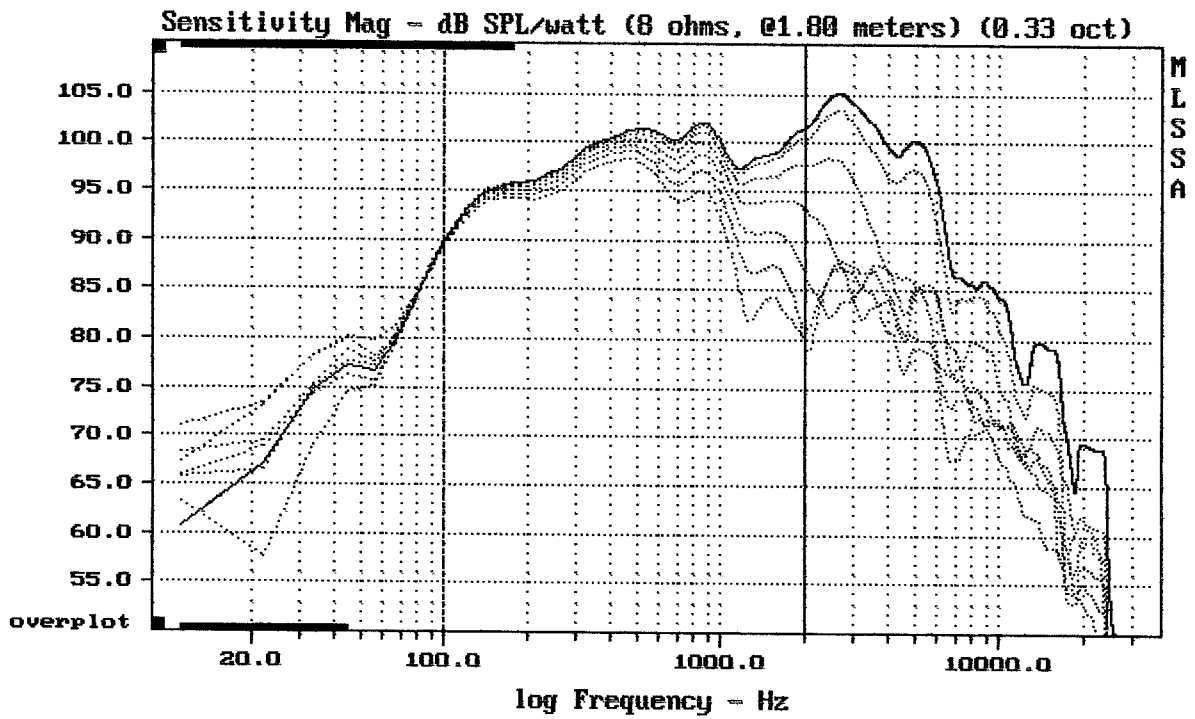

Overlay Compare: dev= +9.9/-11, std= 6.3, avg= -10

12CXL 0/10/...60 DEG.

MLSSA: Frequency Domain

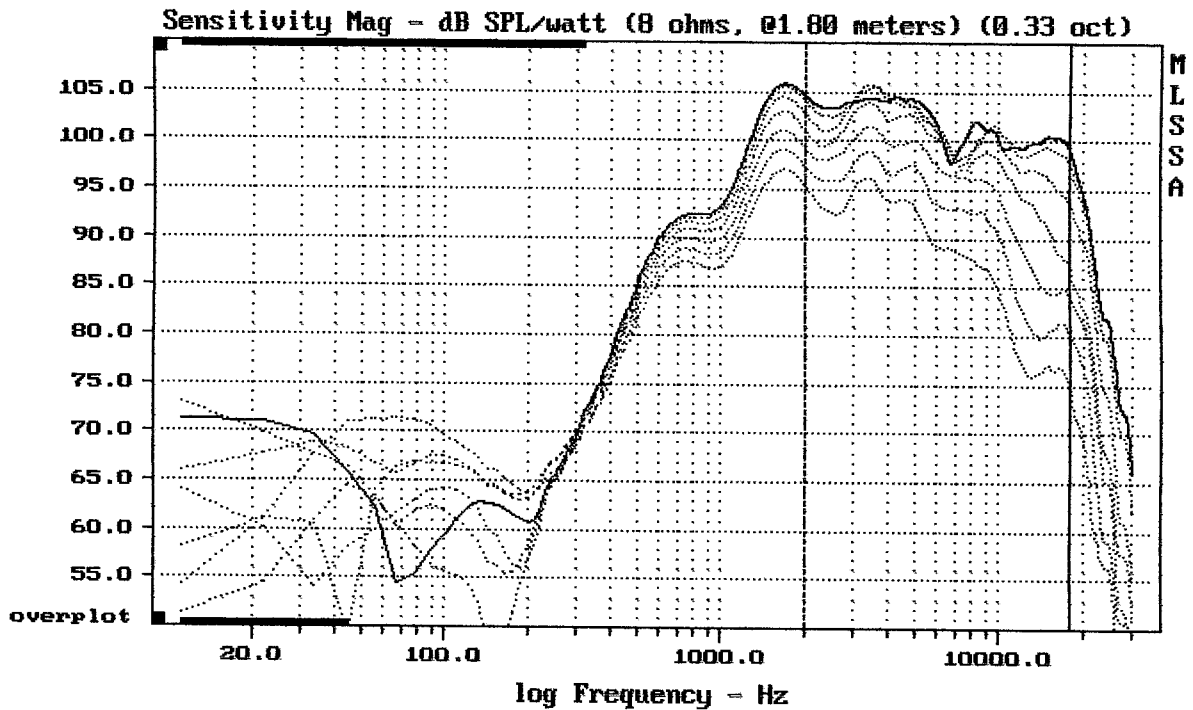

Overlay Compare: dev= +9/-7.6, std= 5.9, avg= -17

12CXL 0/10/...60 DEG.

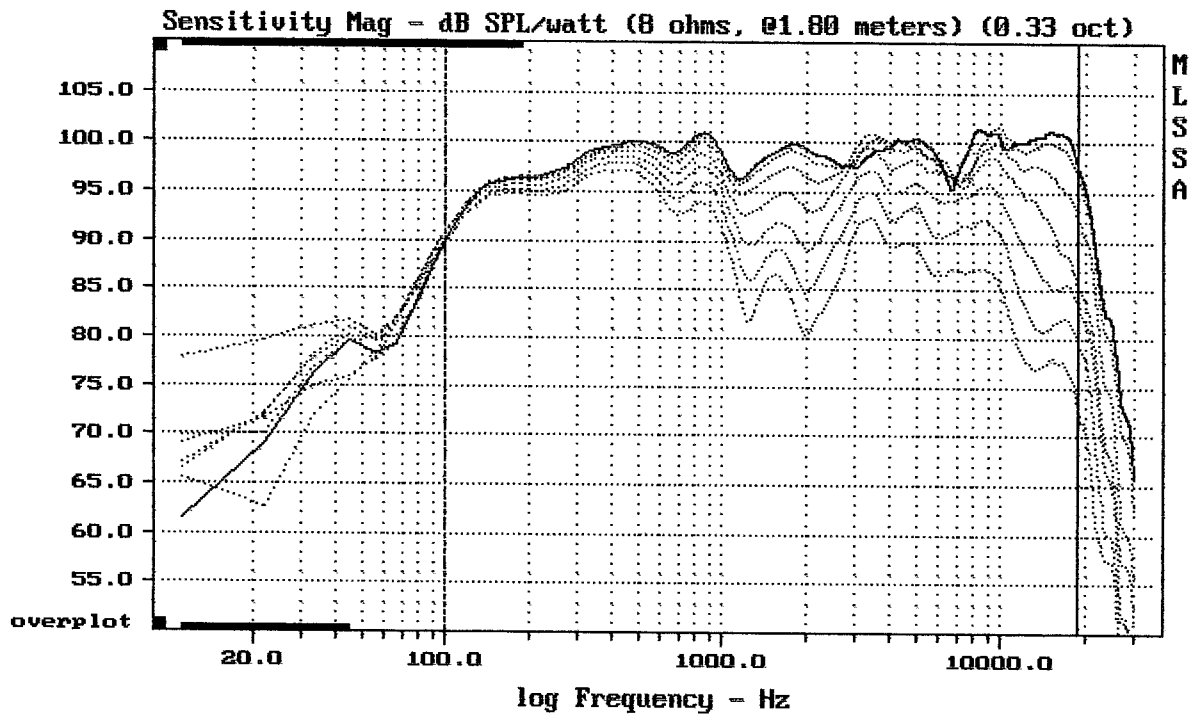

Overlay Compare: dev= +16/-8.5, std= 6.4, avg= -17

12CXL 0/10/...60 DEG.

MLSSA: Frequency Domain

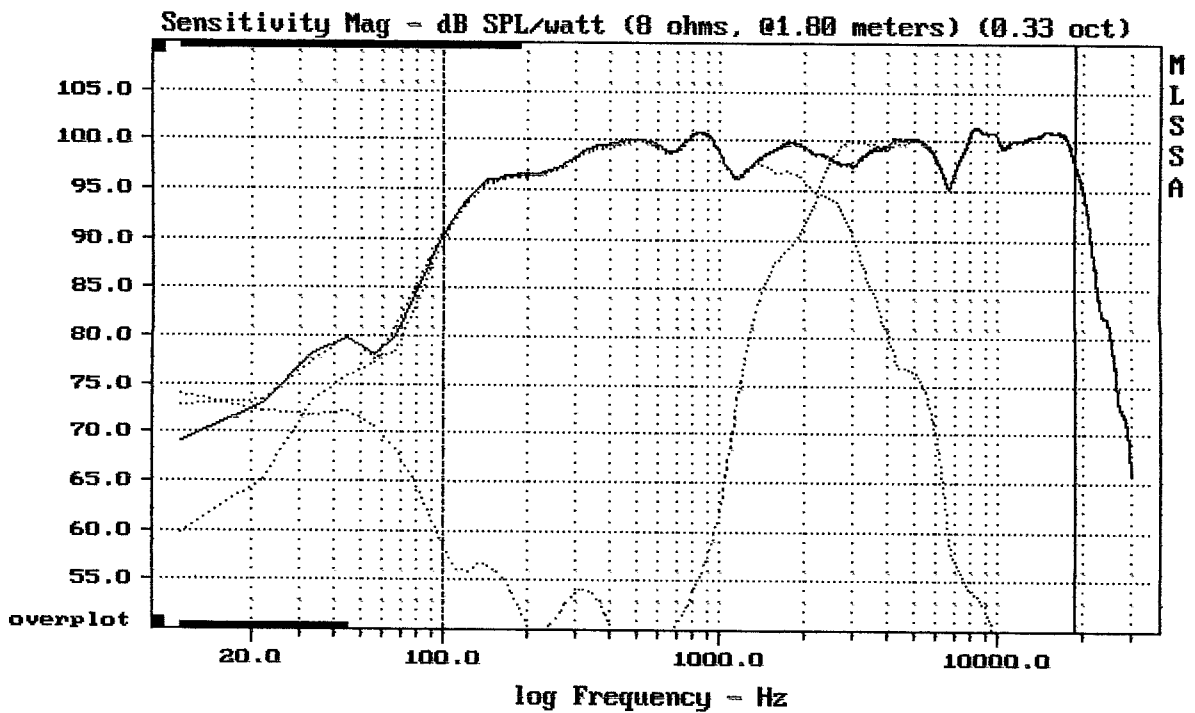

Level (100:19010 Hz) = 98.71 dB SPL/watt (8 ohms, @1.80 meters) (0.33 oct)

12CXL

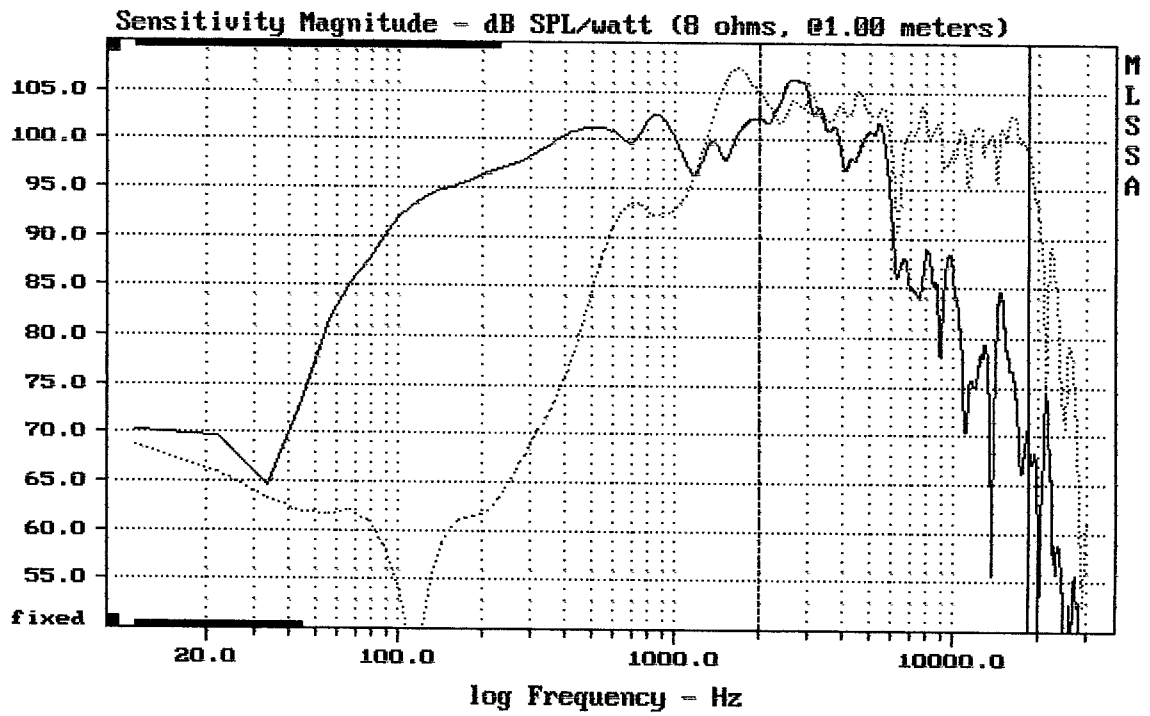

Level (1998:18499 Hz) = 102.06 dB SPL/watt (8 ohms, @1.00 meters)

12CXL

MLSSA: Frequency Domain

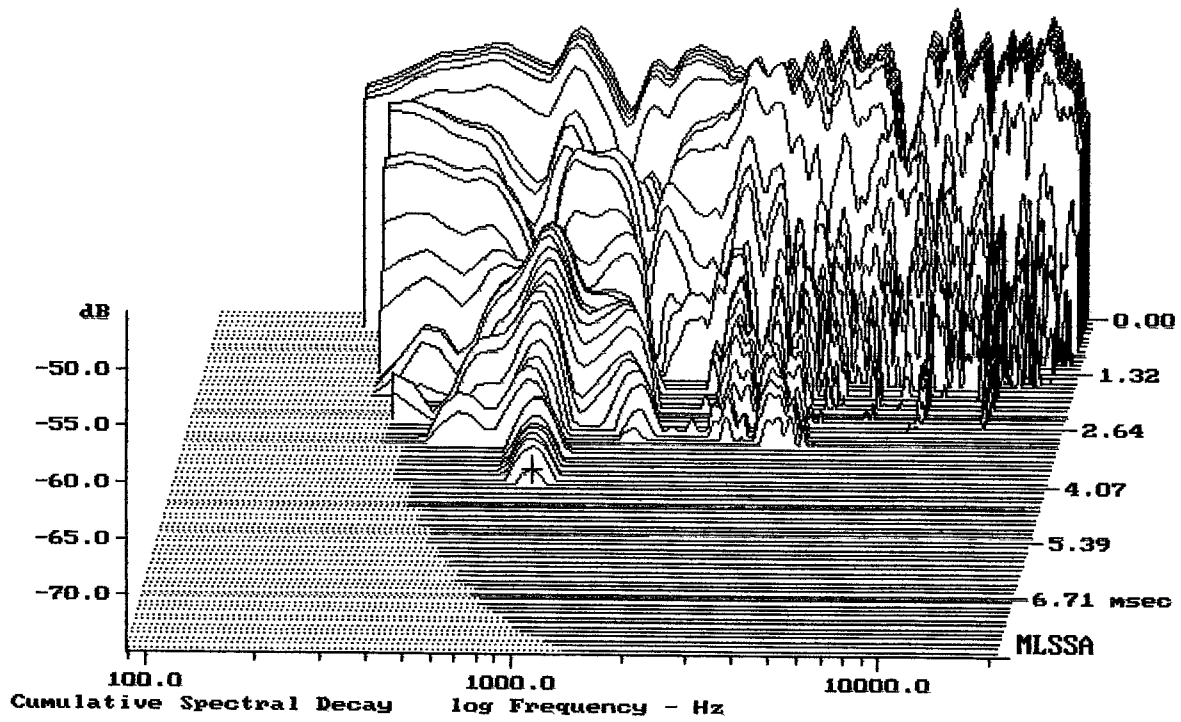

-73.73 dB, 843 Hz (19), 4.070 msec (38)

12CXL

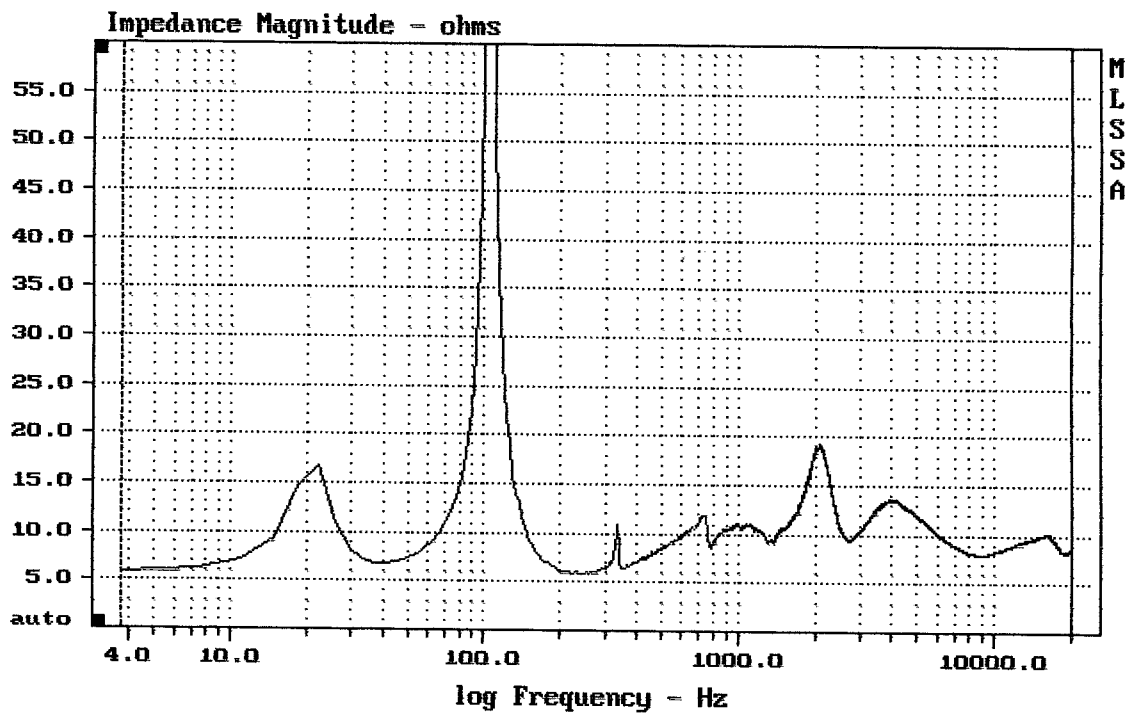

mean: 9.843, rms: 10.17, std: 2.565, max: 86.9, min: 5.771

12CXL

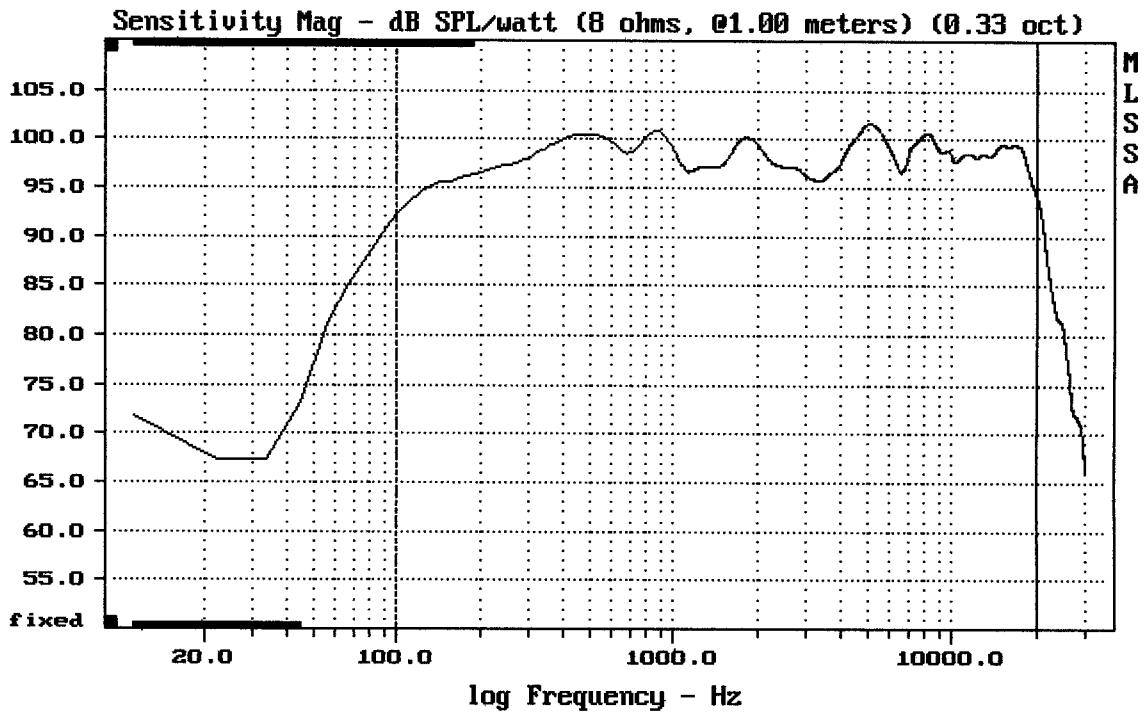

Level (100:20000 Hz) = 98.49 dB SPL/watt (8 ohms, @1.00 meters) (0.33 oct)

12CXL + x-over 12CXT

MLSSA: Frequency Domain

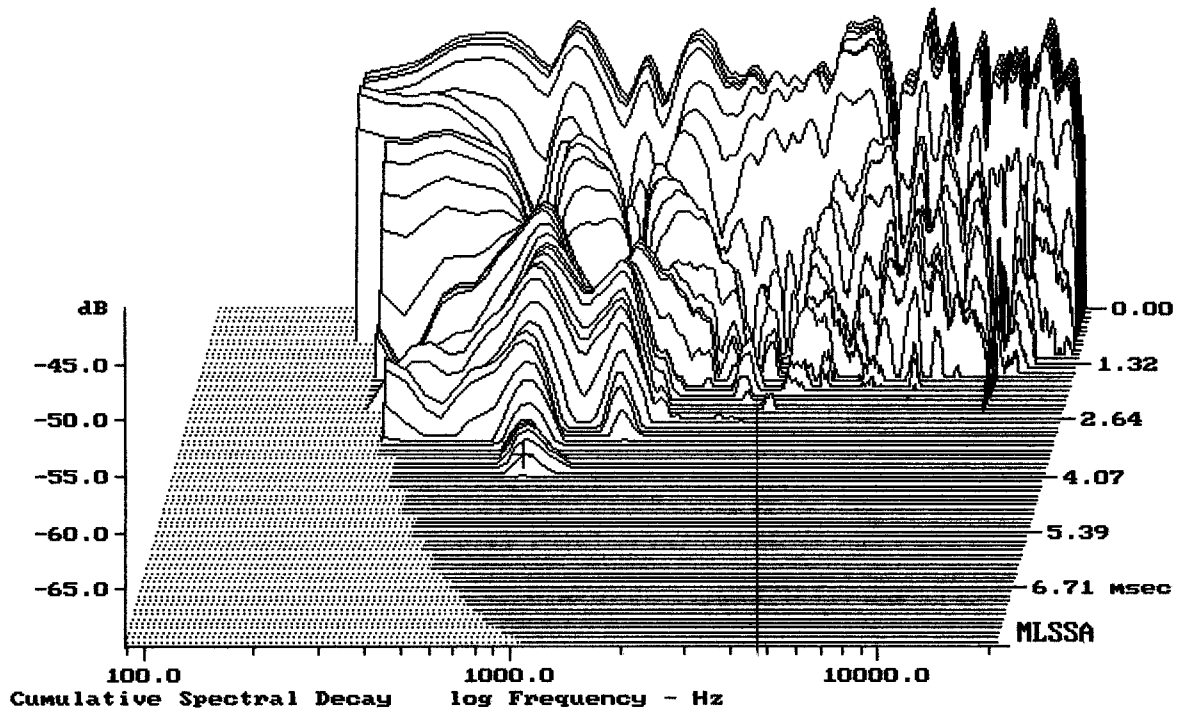

-68.43 dB, 799 Hz (18), 3.960 msec (37)

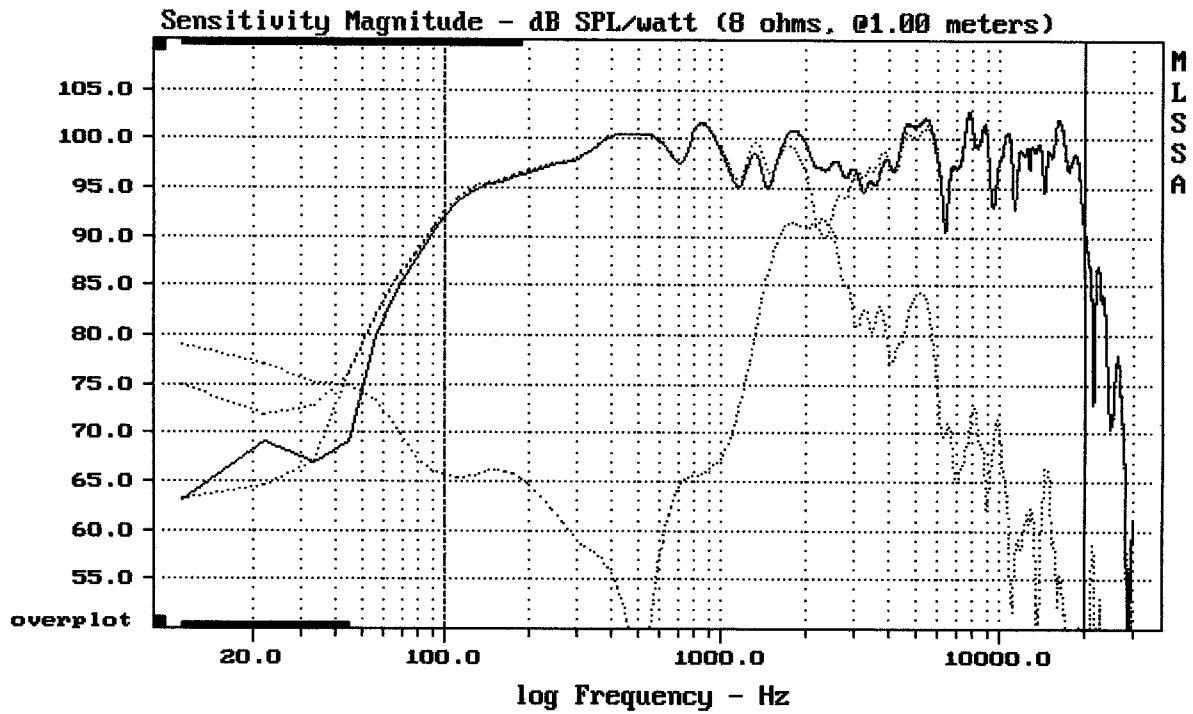

Level (100:20000 Hz) = 98.49 dB SPL/watt (8 ohms, @1.00 meters)

12CXL + x-over 12CXT

MLSSA: Frequency Domain

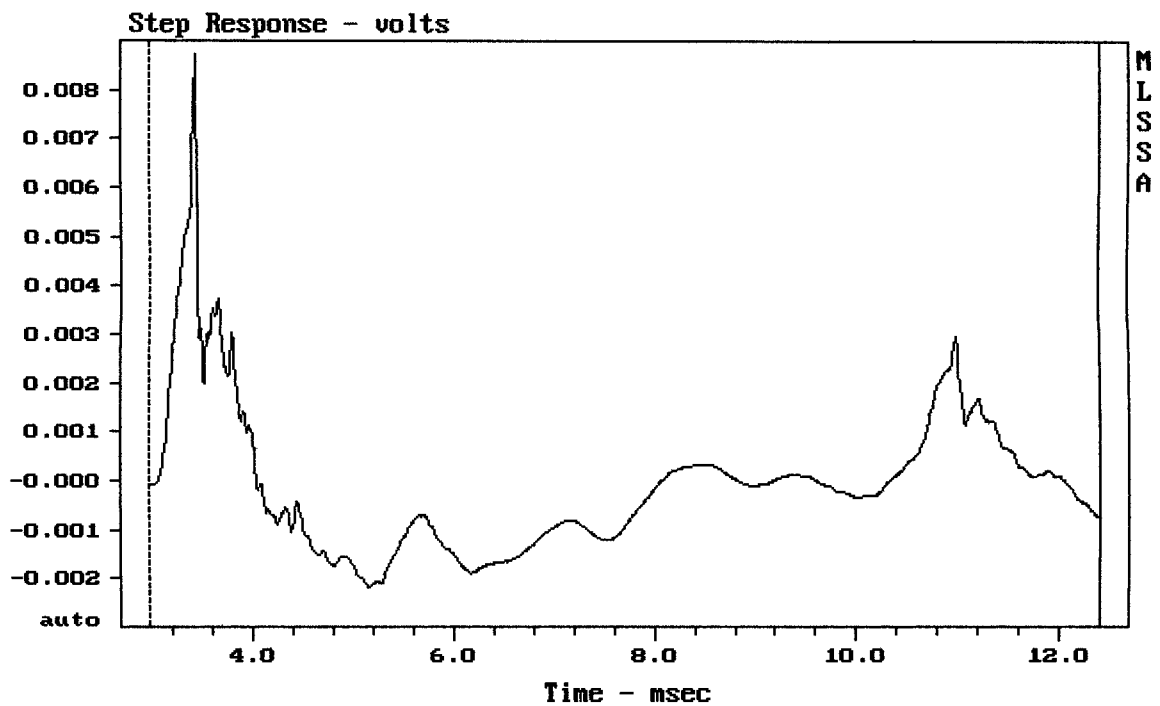

CURSOR: y = -0.000750399 x = 12.3970 (1127)

12CXL + x-over 12CXT

Measured Data

QC Limits

Line	Parameter	Value	Units
1	RMSE-free	0.53	Ohms
2	Fs	65.27	Hz
3	Re	4.79	Ohms[dc]
4	Res	98.19	Ohms
5	Qms	6.66	
6	Qes	0.32	
7	Qts	0.31	
8	L1	0.38	mH
9	L2	1.13	mH
10	R2	5.32	Ohms
11	RMSE-load	0.76	Ohms
12	Vas(Sd)	74.97	liters
13	Mms	31.40	grams
14	Cms	189	$\mu\text{M}/\text{Newton}$
15	B1	13.78	Tesla-M
16	SPLref(Sd)	99.9	dB[Re]
17	Rub-index	0.01	

Method: Mass-loaded (40.00 grams)

Area (Sd): 530.93 sq cm

DCR mode: Measure (-0.07 ohms)

QC file: CLOSED

Analysis successful. Shift in Fs = -31.9% (-20% to -50% is recommended).

12CXL

MLSSA: Parameters

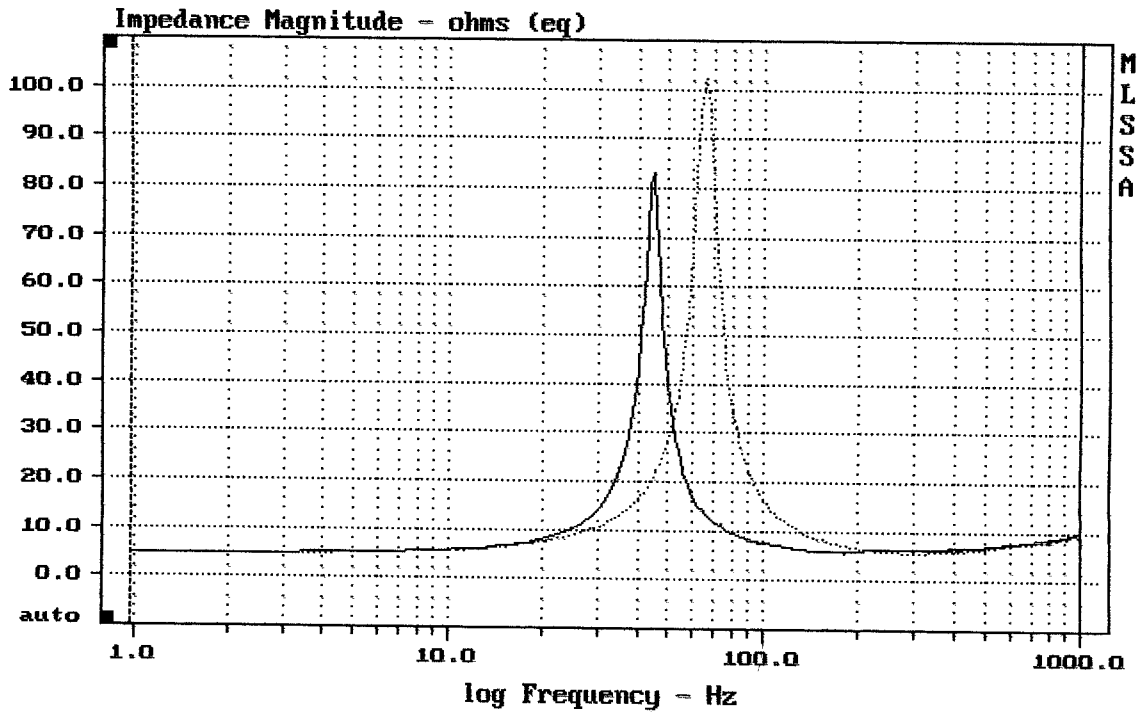

CURSOR: dy = -0.891493 x = 1000.9766 (1025)

DTTO

MLSSA: Frequency Domain