



## General Description

The Rane Model SM 26S Splitter Mixer is one of the most useful, yet unusual audio products available. In its most basic configuration, it is a six-to-two line level mixer. It will accept six balanced or unbalanced line level inputs which are applied to six Level and Pan controls. An additional stereo Master Input allows a total of eight inputs. The result of the mix is sent to an overall Master Output Level control and appears at the Left and Right Outputs on the rear. In its splitter mode, the SM 26S can take one or two line level inputs and split these to any of the six Mono Outputs on the rear. The Mix/Pan controls in this mode control the level from each of the two input buses to be applied to each Output. Internal header blocks allow the Mix Outputs to become an independent stereo out, allowing a total of eight outputs. The SM 26S may also be used as a six input, six output buffer amplifier in which case signal applied to Input 1 is delivered to Output 1, and so on.

## Features

- -10 dBV to +4 dBu Shifter
- +4 dBu to -10 dBV Shifter
- 6 Balanced Mono Inputs, 6 Balanced Mono Outputs
- 2 Main Balanced Inputs, 2 Main Balanced Outputs
- 6 Input Level Controls and 6 Mix/Pan Controls
- Master Input and Output Level Controls
- NEW! Internal Universal Power Supply (100-230 VAC)

The SM 26S may also be used in a combination of modes at once. For instance, Inputs 1 through 3 may be mixed to the left and/or right output buses while at the same time Outputs 4 and 5 are delivering signal originally applied to the Left and Right Master Inputs while at the same time Output 6 is being driven from Input 6 in the straight through mode.

The front of the SM 26S comprises a Master Input Level control, six Channel Level controls, six Mix/Pan controls and a Master Output Level control. The rear of the SM 26S provides two Master Left and Right Inputs, six Mono Inputs, six Mono Outputs and two Master Left and Right Mix Outputs. All Inputs and Outputs on the SM 26S are ¼" TRS active balanced.

See the RaneNote, *"The SM 26S Swiss Army Mixer"* for additional application information, available from our website.

## Applications

- 6 Mono Inputs, Stereo Output Line Mixer
- 4 Stereo Inputs, Stereo Output Line Mixer
- Stereo Input, 6 Mono Output Line Splitter
- 1 Stereo Input, 4 Stereo Output Splitter
- 6-In, 6-Out Booster Amplifier
- Configurable to 8 Outputs



**Features and Specifications**

Parameter	Specification	Limit	Units	Conditions/Comments
Inputs: Type	Active Balanced			
.....Connectors	¼" TRS			Tip=(+), Ring=(-), Sleeve=GND
.....Impedance	20k	1%	Ω	
.....Maximum Level	22	1	dBu	
Outputs: Type	Active Balanced			
.....Connectors	¼" TRS			
.....Impedance	125	typ	Ω	1 kHz
.....Maximum Level	26	1	dBu	10 kΩ or greater
Overall Gain Range	Off to +12	-0/+6	dB	Any Input to any Output
RFI Filters	Yes	5%		
Frequency Response	10-40 kHz	+0/-3	dB	
THD+Noise	0.008	.002	%	+4 dBu, 20-20 kHz unity gain
IM Distortion (SMPTE)	0.009	.002	%	60 Hz /7 kHz, 4:1, +4 dBu unity gain
Signal-to-Noise Ratio				re +4 dBu, 20 kHz noise bandwidth
	120	2	dB	Mono Outputs, unity gain
	98	2	dB	Mix Outputs, unity gain
Crosstalk				
.....L-R Panning	60 (1 kHz)	2	dB	Any Input to Mix Outs
.....Channel-Channel	75 (1 kHz)	2	dB	Any Input to Mix Outs
Mean Time Between Failure	35,500 hours		h	Mil-Hdbk-217D, Section V
Unit: Maximum Power	7		W	
.....Universal Line Voltage	100 to 240	10%	VAC	50/60 Hz
.....Agency Listing	UL/cUL/CE			
Unit: Construction	All Steel			19" 1U Rackmount
.....Size	1.75" H x 19" W x 5.3" D			(4.4 cm x 48.3 cm x 13.5 cm)
.....Weight	5 lb (w/o power supply)			(2.3 kg)
Shipping: Size	4.25" x 20.3" x 13.75"			(11 cm x 52 cm x 35 cm)
.....Weight	9 lb			(4.1 kg)
<i>Note: 0 dBu=0.775 Vrms</i>	<i>Unity Gain = Master Levels Set to - "7" Position</i>			

### Block Diagram

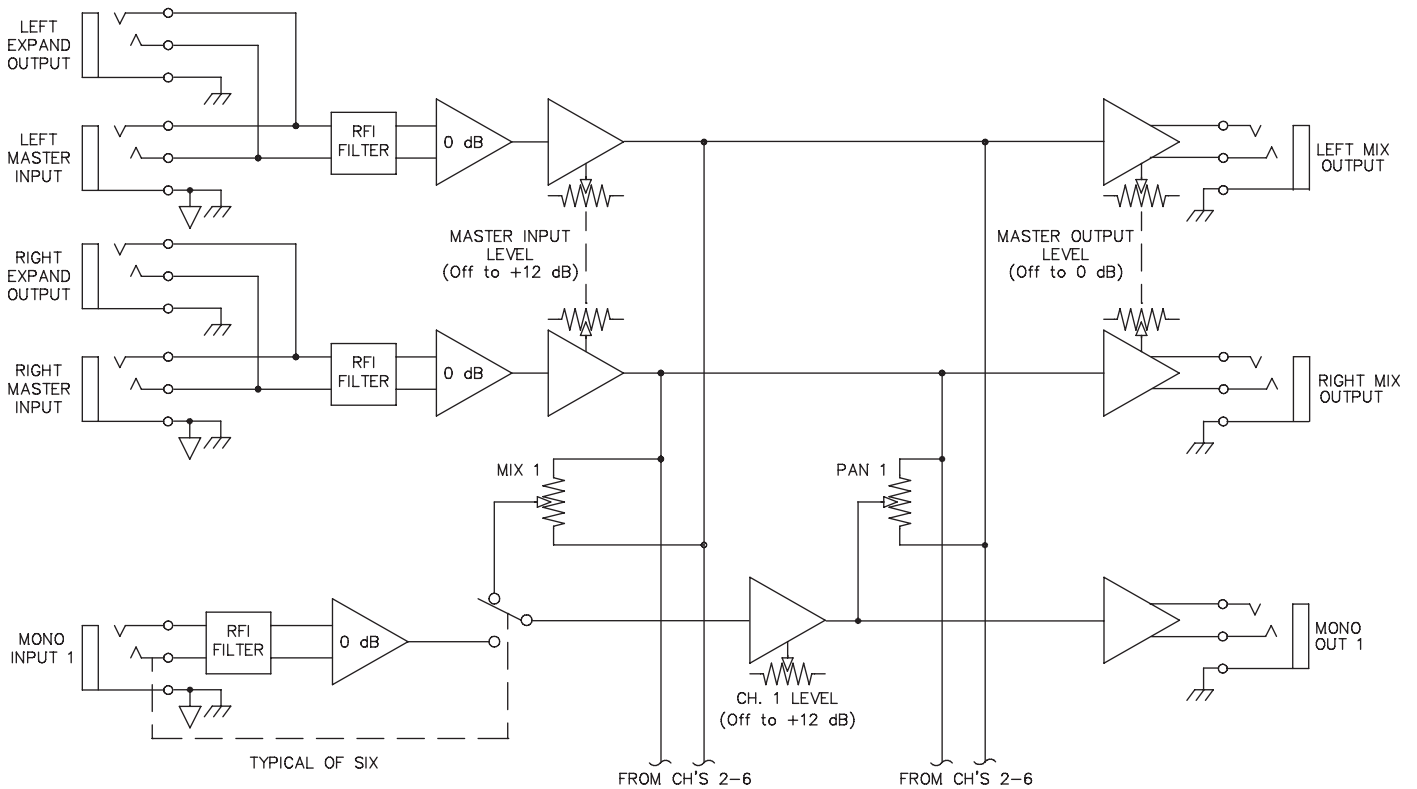

### Application Information

Aptly nicknamed the “Swiss Army Mixer”, the SM 26S is an extremely versatile single rack-space tool providing a number of different functions to solve a broad spectrum of line-level signal routing problems. Whether the need is for line mixing, line distribution or line matching/amplification, the SM 26S easily performs these tasks, along with additional features for even more flexibility.

One of the most popular uses is line-level mixing for keyboards, drum machines, and effects. Expanding existing console limitations is simple. Whenever a mono or stereo sub-mix is desired, the SM 26S comes to the rescue. Up to three stereo, or six mono sources easily mix together, with panning ability on every input. Many musical instrument performers find the SM 26S indispensable for combining various effects and expanding the available loops on their signal processors.

The SM 26S capabilities also include a wide variety of functions such as live recording splitting, -10 dBV to +4 dBm level matching, intercom splitting, line boosting, hotel and club zone

management, restaurant paging systems, adding additional monitor buses for studio or stage use, and many more custom applications. Please consult the RaneNote “*The SM 26S Swiss Army Mixer*” for in-depth applications.

The SM 26S provides full expansion capabilities for all applications. Simple ¼" TRS connectors allow expansion using patch cords. Using these provisions, an unlimited number of lines may be mixed or split upon demand. For example, three units create either an 18 input mixer or an 18 output splitter, or a combination of both.

The question arises regarding mic levels. Since the SM 26S operates only at line levels, microphone applications require separate boosting before connection. Rane offers a mic stage model MS 1b ideally suited to this application. The MS 1b is a single channel mic preamplifier with a true differential input and balanced output. This provides the ability to locate the mic preamp close to the mic’s location.

## Rear Panel



## Architectural Specifications

The splitter mixer unit shall have six (6) mono inputs, six (6) mono outputs, two (2) master inputs, and two (2) master outputs. The unit shall be capable of mixing or splitting any inputs to any outputs simultaneously. Each mono input shall have a level control with a range of off to +12 dB gain. Separate +12 dB gain Master Input and Output Level controls shall be provided.

Complete expansion capabilities shall be provided to allow any number of similar units to be coupled together.

A combination Mix or Pan control shall be provided on each of the six (6) mono channels to allow any output to be a mix of

the two master inputs, or to allow any mono input to be panned between the two master outputs.

The inputs and outputs shall be active balanced designs terminated with ¼" TRS (tip-ring-sleeve) connectors. RFI filters shall be provided. Ultrasonic filters shall be built-in.

The unit shall be capable of operation by means of its own built-in universal power supply operating at 100-240 VAC and meet CE requirements (pending). The unit shall be UL and cUL listed (pending). The unit shall be entirely constructed from cold-rolled steel.

*The unit shall be a Rane Corporation SM 26S.*

## Available Accessories

- SC 1.7 Security Cover
- MS 1B Microphone Preamp